

UDS2-73

Complies with: EN 16729-1



**Ultrasonic
Double Rail
Flaw Detector**

UDS2 - 73 Ultrasonic Double Rail Flaw Detector

Main technical specifications

UDS2-73 rail flaw detector is intended for continuous inspection of rails and railway switches at a speed of 3 km/h and flaw detection in rail cross section, excluding rail base blades, as well for manual confirmatory testing of individual rail crosssections and welded joints.

The flaw detector offers recording of test results both in a database format (B-Scan) and as individual test reports linked to path and GPS coordinates.

UDS2-73 ultrasonic double rail flaw detector

The flaw detector performs non-destructive testing of rails by pulse-echo, echo-mirror and echo-image technique, using contact ultrasonic probes.

The ultrasonic testing provided by UDS2-73 is compliant with EN 16729-1 "Railway applications - Infrastructure - NDT on rails in track - Part 1: Requirements for ultrasonic inspection and evaluation principles", ETN-01-04 "Manual for Non-destructive Testing of rails" and other regulations.

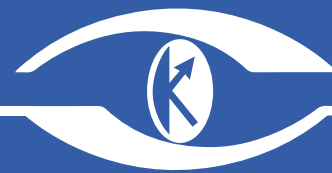

OKOndt GROUP



Main specifications

- The flaw detector consists of an electronic unit, four multiplexer units, probe units, a storage battery, couplant tanks and a trolley;
- Rail flaw detector performance complies with EN 16729;
- Number of channel (probes): 26 probes (sliding probe unit SPU) or 22 probes (Roller search unit Immersion RSUI) (13 or 11 probes per each rail);
- Probe type and frequency: 0° /4MHz, $+70^{\circ}$, $+58^{\circ}$, $+45^{\circ}$ /2.5MHz; RSUI: 0/4, $+70$ (central, guage side, field side), $+50$ (SL), $+45(37)$ / 2MHz;
- Types of inspected rails: S60, S49, UIC60, 60E1, 49E1 and others;
- Scanning pitch - 1mm, at a speed of 4 km/h;
- Display modes: A-scan, B-scan and A-Scan+B-Scan;
- Continuous test result recording as a database format linked to path and GPS coordinates;
- Test result reviewing mode on the screen of the flaw detector;
- Flaw detector weight without couplant - no more than 55 kg for SPU; 65 kg RSUI;
- Couplant tank volume: 2x10l;
- Couplant consumption: up to 3l/ at a speed of 4 km/h.



Sliding Probe Units

OKO_{ndt} GROUP



Ultrasonic Double Rail Flaw Detector UDS2 - 73

The flaw detector comprises two probe units:

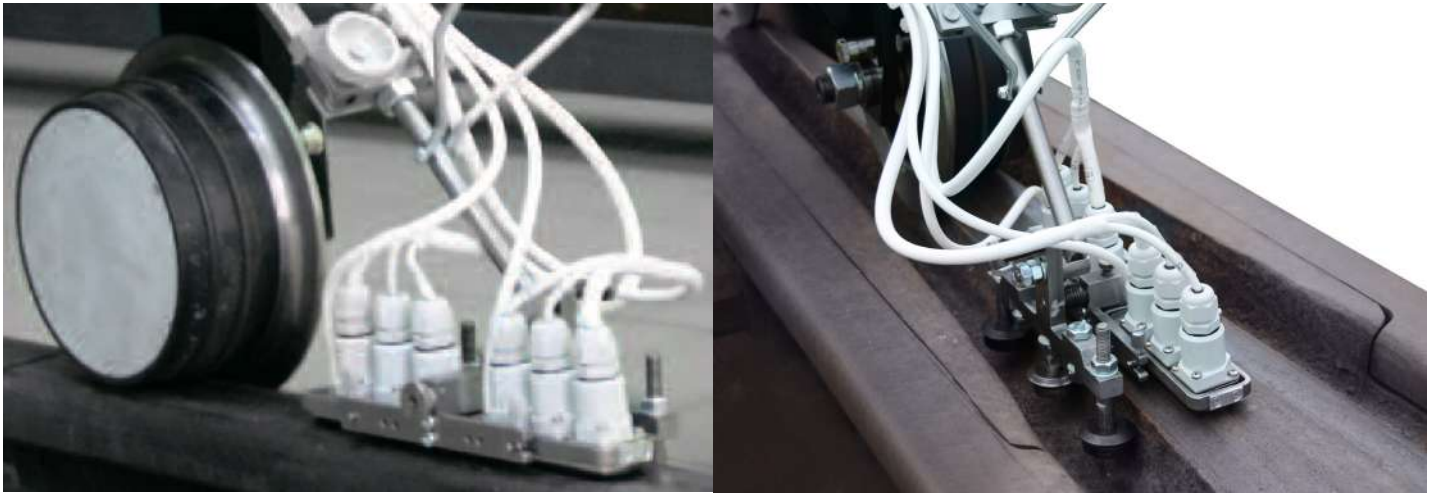

Probe Unit 1:

- Probe 00 — 4 MHz;
- Probe 700 -2.5 MHz (Forward scanning)
- Probes 4x580x340 - 2.5 MHz (Forward/ backward scanning).

Probe Unit 2:

- Probe 4x580x340 - 2.5 MHz; (Forward/ backward scanning)
- Probe 700 -2.5 MHz (Backward scanning)
- Probe 2x450 - 2.5 MHz (Forward/ backward scanning)

Sounding Schemes

SCHEME 1

Pulse-echo method of rail head inspection with 58°x 34° probe.

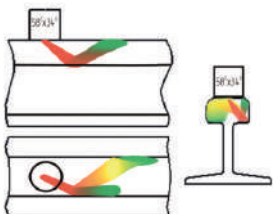

SCHEME 2

Pulse-echo method of rail head inspection with two 58°x 34° probe.

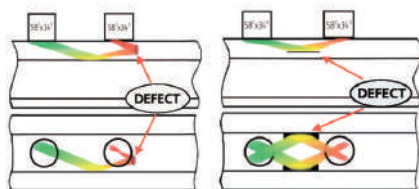

SCHEME 2

Pulse-echo method of rail head web and foot inspection with standard 0°, 70°, 45° probes.

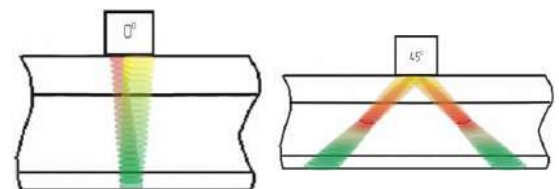

Sliding Probe Units

Ultrasonic Double Rail Flaw Detector UDS2 - 73

OKO_{ndt} GROUP

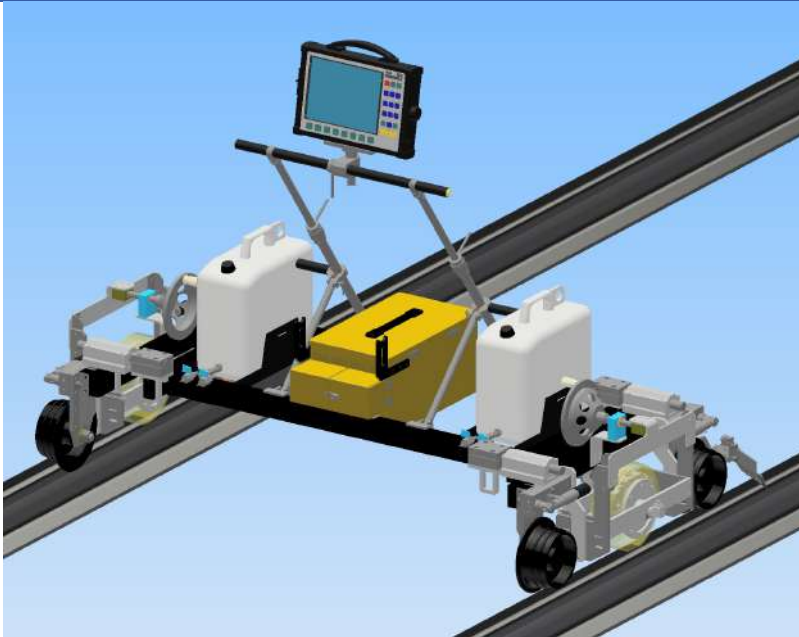

Number of ultrasonic probes 11

0°-4 MHz

70°-2 MHz (Head Central Forward)

70°-2 MHz (Head Central Backward)

70°-2 MHz (Head Gauge Face Forward)

70°-2 MHz (Head Gauge Face Backward)

70°-2 MHz (Head Field Face Forward)

70°-2 MHz (Head Field Face Backward)

2x40°- 2 MHz (Web, Foot Forward / Backward)

2x50°- 2 MHz (Head Side Looking)

UDS2-77 AREMA (RSU) WHEEL PROBE

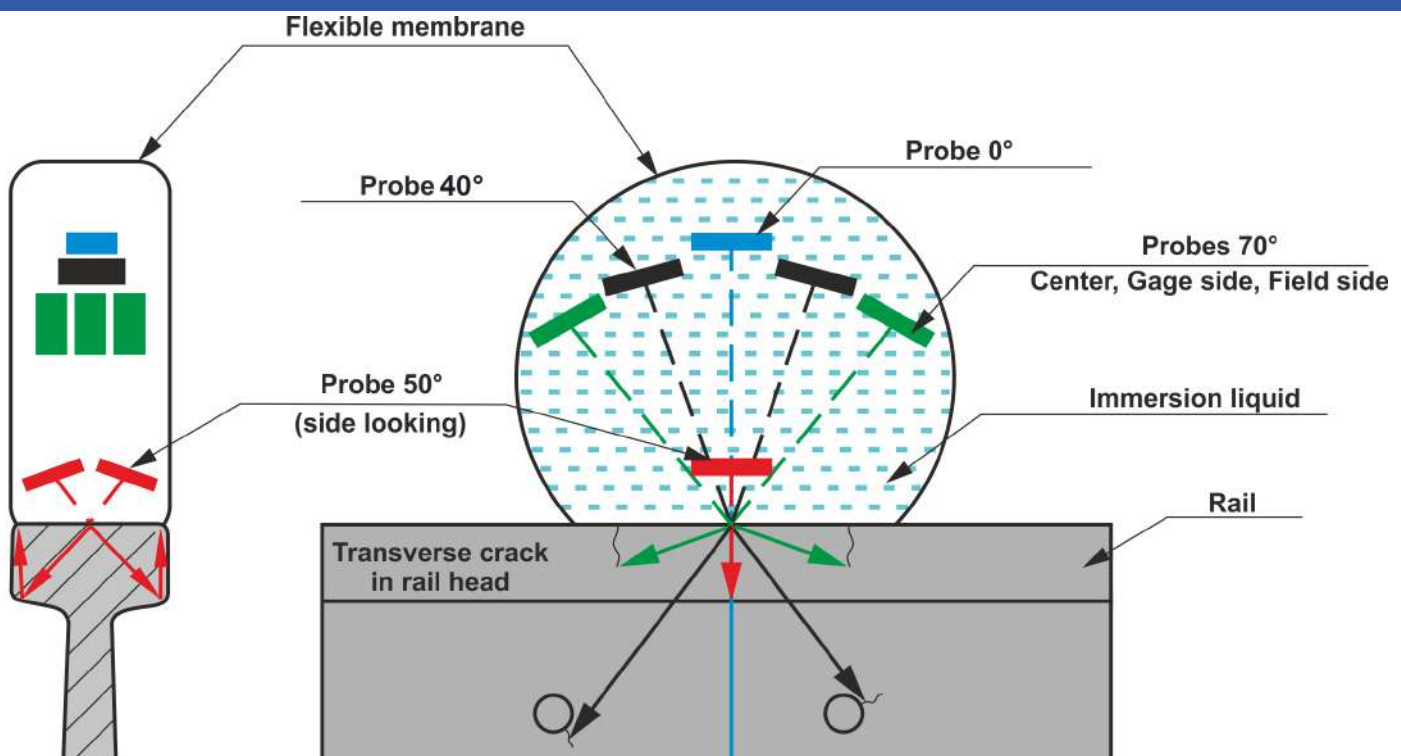

Interface and main modes of the flaw detector software



General flaw detector interface



Display mode: A-Scan for one channel

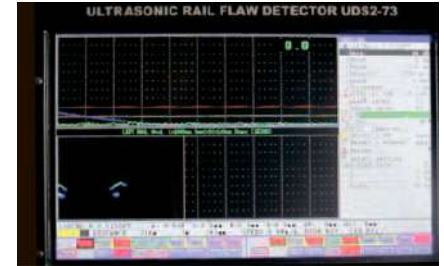

Display mode: A-Scan + B-Scan for one channel

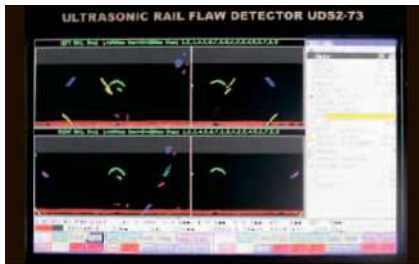

Display mode: B-Scan for one channel

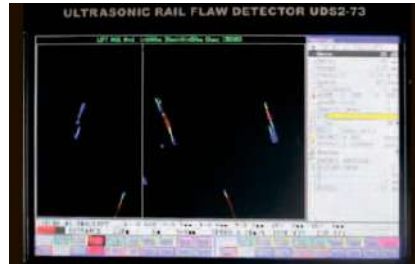

Display mode: B-Scan for one channel

Software for test result analysis and evaluation

The "Rail Inspector" program is intended for display, analysis and evaluation of test results on PC. The program utilizes all the necessary tools to process data.

The major advantages of the program are:

Convenient work with the database of inspected sections (stages);

Selection of the layout of inspection channels, selection of an inspected rail, inspected rail segment, testing method;

Measuring the notional size of defects in B-Scan mode;

Viewing A-Scan based on the data recorded in B-Scan;

Viewing a defectogram (B-Scan) in scroll mode or in mode of fast switch to the given coordinate;

Path marking mode to mark suspicious segments of rail track while viewing test results;

Sorting out test results by sensitivity level from -6 to +6 dB above or below the measuring gate level;

Mode of viewing and producing reports on the inspected segment;

Mode of viewing reports on confirmatory testing.

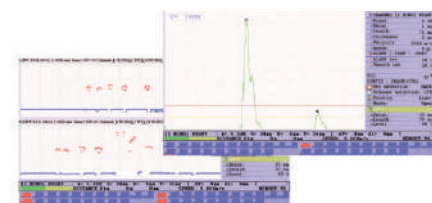
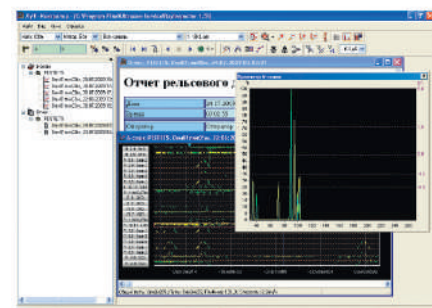

Position marks	
Instrument labels	User labels
Rail	Description
31km 105m 896mm	This rail section should be retested
31km 105m 604mm	
31km 105m 287mm	

Ultrasonic Double Rail Flaw Detector UDS2 - 73



OKO_{ndt} GROUP

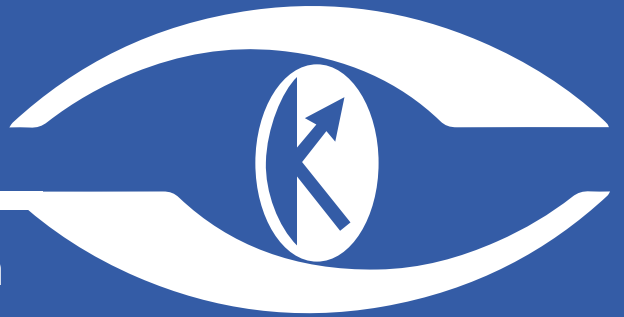

E-mail: global-sales@oko-ndt.com
www.oko-ndt.com

